

LifeStar Ambulance Power Module

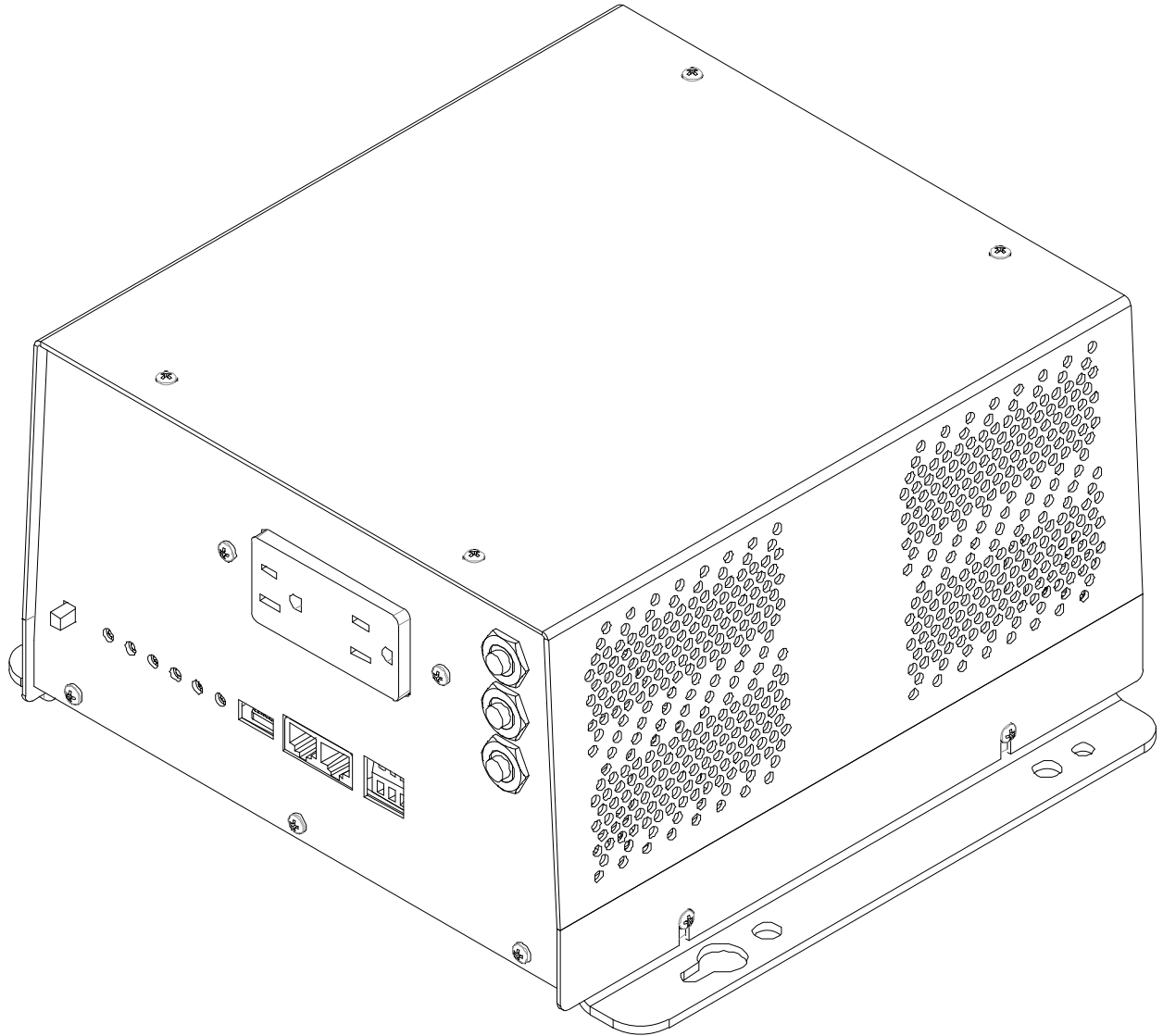

Model

20-1050CUL-DC
20-1000TUL-DC

Table of Contents

Table of Contents.....	2
Section 1 : General Installation Diagram.....	3
Section 2 : Introduction.....	4
Section 3. Functionality	4
Inverter Function	4
Battery Charger	5
DC Power Output.....	5
Section 4: Specifications	6
Unpacking the Ambulance Power Module	7
Installing the Ambulance Power Module.....	7
Inverter Lamp Description	9
Section 6: Installing the Inverter and Charger Remote Status Display Panels	10
Section 7: Operating the 20-1050CUL-DC Ambulance Power Module	11
Section 8: Troubleshooting the 20-1050CUL-DC	12

Section 1 : General Installation Diagram

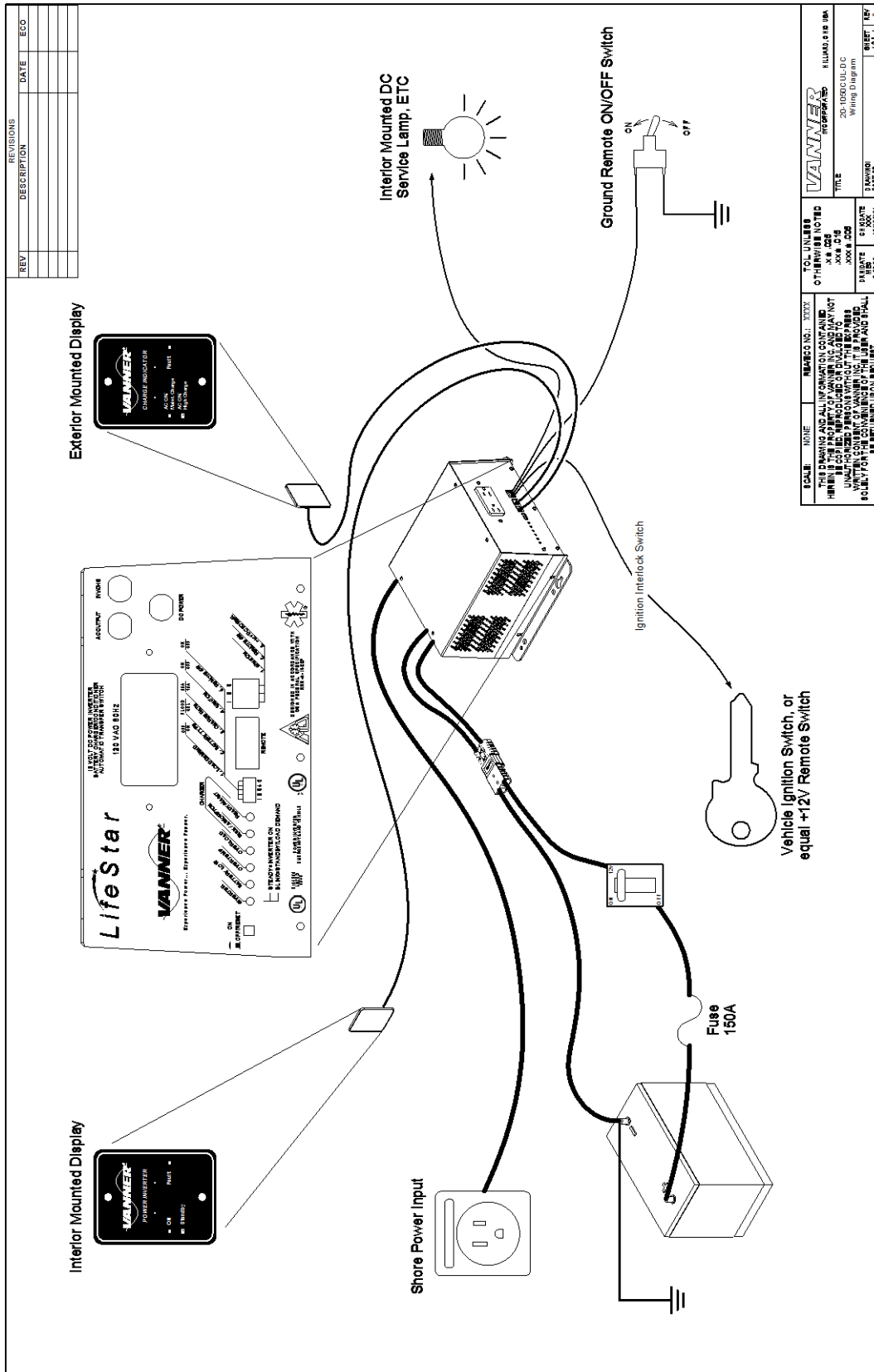

Section 2: Introduction

Thank you for purchasing a Vanner Ambulance Power Module for your emergency vehicle. We are confident you will be satisfied with its performance.

Vanner products are designed and manufactured by skilled professionals using the highest standards in workmanship, guaranteeing excellent performance and reliability for your emergency vehicle. With minimum maintenance and care, you can expect years of trouble-free service from your Vanner product.

The 20-1050CUL-DC is a 12 VDC to 120 VAC inverter with a built-in battery charger/conditioner, transfer relay and KKK Spec 12V Portable Equipment Charging Circuit. This unit is equipped with an AC line cord for connecting AC input power (shore/utility power) and a receptacle with a Ground Fault Circuit Interrupter (GFCI) for AC output. This enables you to plug AC loads directly into the inverter. The DC cables have quick connectors to facilitate installation and pre-wiring of emergency vehicles. The 12V Portable Equipment Charging Circuit has a spring clamp for ease of installation. **The transfer relay is powered by +12Vdc, the unit must be connected to the DC source for the transfer relay to work.**

The 20-1000TUL-DC is a 12 VDC to 120 VAC inverter with transfer relay and KKK Spec 12V Portable Equipment Charging Circuit. This unit is equipped with an AC line cord for connecting AC input power (shore/utility power) and a receptacle with a Ground Fault Circuit Interrupter (GFCI) for AC output. This enables you to plug AC loads directly into the inverter. The DC cables have quick connectors to facilitate installation and pre-wiring of emergency vehicles. The 12V Portable Equipment Charging Circuit has a spring clamp for ease of installation. **The transfer relay is powered by 120VAC, the transfer relay will engage without the unit being connected to the DC source.**

This manual is written around the 20-1050CUL-DC, all sections of this manual that refer to the Charger section of the unit does not apply to the 20-1000TUL-DC.

Section 3: Functionality



WARNING : Battery input cables must be connected to the battery with proper polarity to avoid damaging the inverter.

NOTE : If the battery is fully charged at the time AC input is applied, the unit will go directly into Ready/Maintenance mode.

Inverter Function

The 20-1050CUL-DC converts battery power to 1050 Watts of 120 VAC modified sine wave power to operate vital emergency vehicle equipment. The unit is easily connected to the positive and negative posts of a battery system with appropriate fusing, and when turned on, produces 120 VAC True RMS voltage.

The inverter also has an energy-saving feature called Load Demand. With this feature, the inverter output is pulsed, significantly reducing the current draw from the battery until a demand is made on its output. Continuous output of 120 VAC resumes when a load greater than 20 Watts is applied. The load demand feature can be disabled with the Setup Switch on the front panel.

A built-in transfer relay switches the AC output receptacle from the inverter to the AC input when the unit senses AC input from the shore/utility power.

Battery Charger

The 20-1050CUL-DC Battery Charger's superior design incorporates a multi-stage charger. This design enables the unit to automatically charge batteries, maintaining the battery's integrity and reducing the likelihood of premature failure.

* Bulk Absorption Charge Mode

While in the Bulk Charge mode, the unit continuously charges at a constant current of 55 Amps (high setting) this is the factory setting, or 15.0 Amps (low setting) The unit will charge until battery voltage reaches 14.2 VDC for flooded battery setting, or 14.1 VDC for gel battery setting. The unit then supplies a fixed voltage for one hour.

* Ready/Maintenance Mode

The charger automatically enters the Ready/Maintenance mode, maintaining the battery's proper voltage of 13.2 VDC for flooded battery setting, or 13.6 VDC for gel battery setting. This Ready/Maintenance mode is designed to eliminate gassing (overcharging), helping to extend the life of the battery.

A Setup Switch is located on the front panel for selecting the type of battery (Flooded Lead Acid or Gel Lead Acid), charger output current (High/Low), and Load Demand (On/Off).

Remote Control

Built-in remote control capability is provided for use with a customer supplied +12v signal and with a customer supplied Ground signal. Either one, both or neither may be used.

To activate +12v remote control set the dip switch labeled IGNITION to the ON position. Connect the +12v remote control signal wire to the compression terminal labeled IGNITION.

To activate GROUND control set the dip switch labeled REMOTE to the ON position. Connect the GROUND control signal wire to the compression terminal labeled REMOTE.

If no remote control is required set both dip switches to the OFF position.

The unit can be used with the IFM1 Interface Module and is fully backward compatible for retrofitting installations that already have the IFM1 Interface Module. To use the IFM1 set the dip switches labeled IGNITION and GROUND to the OFF position. Plug the IFM1 modular cord into either 8-pin socket.

DC Power Output

The 20-1050CUL-DC DC Power Output complies with KKK section 3.7.7.2 for PORTABLE EQUIPMENT CHARGING CIRCUIT. Which states "*A circuit shall be furnished for charging all portable battery powered devices, i.e. suction units, hand lights, portable radios, etc. This circuit shall prevent discharge of chassis batteries by only permitting the charging of portable devices when the vehicle is either running or the optional battery conditioner is connected to shore power. Circuit breaker protection shall be provided and shall have a minimum 10 amp capacity. An additional tagged, identified lead shall be furnished in both the cab and module for connection of additional (future) portable equipment that requires recharging.*"

DC Power (battery power) is available while +12V Remote Switch Terminal is energized and while the 20-1050CUL-DC is in battery charger mode. DC output is protected by a 20A circuit breaker label "DC Power"

Section 4: Specifications

Inverter	20-1050CUL-DC	20-1000TUL-DC
Output at 120 VAC RMS (Continuous Power Rating)	1050 Watts	
Surge Capacity at 120 VAC (3 sec)	2100 Watts	
Input Voltage, VDC (Deep Cycle Battery Recommended)	12 VDC, Nominal 10.5 VDC min, 16.0 VDC max.	
AC Output Voltage	120 VAC ± 5%	
DC Current Draw (Battery)		
OFF	0.017 Amps Typical	
In Load Demand	0.09 Amps Typical	
Full ON at No AC Load	0.7 Amps Typical	
Full On with Load	Approx. AC Load Watts ÷ 10	
Frequency	60 Hz ± 0.2%	
Output Wave Form	Modified Sine Wave	
Battery Charger		
Charging Capacity (note "DC Source" section below)	55 Amps (High) 15 Amps (Low)	N/A
Input Voltage	120 VAC ± 10%	N/A
Input Current	12.0 Amps	N/A
Bulk Voltage	14.2 VDC (flooded), 14.1 VDC (gel)	N/A
Float Voltage	13.2 VDC (flooded), 13.6 VDC (gel)	N/A
Bypass Transfer		
Output Current, GFCI Outlet *	12 Amps	
DC Source		
Output Voltage	Battery Voltage	
Output Current	20.0 Amps Max. (Current must be subtracted from "Charging Capacity" above)	
Other Specifications		
AC Input Termination**	3ft. Line Cord	
AC Output Termination	Duplex GFCI Receptacle	
Ambient Temperature	-20° to +110°F, -29° to +43.4°C	
Cooling Air	Fan Cooled	
Chassis	Aluminum	
Dimensions	11.57"W x 5.94"H x 11.04"D	
Weight	22 BS	

* Note: If GFCI trips and the inverter is in Load Demand mode the GFCI may not reset until you toggle inverter off and back on then you will have 5 seconds to reset GFCI before unit goes back into Load Demand mode again or you can disable Load Demand mode via dipswitch, if available.

** AC input branch rated overcurrent protection is to be provided by others to comply with the National Electric Code, NFPA 70.

Section 5: Installing the 20-1050CUL-DC

Unpacking the Ambulance Power Module

Inspect the shipping container and equipment for loose or damaged parts. If any damage is found, immediately notify the freight carrier.

Installing the Ambulance Power Module

1. Verify the inverter ON OFF/Reset switch is in the OFF position (The button should NOT be pushed in.) Make sure power to the vehicle wiring harness is disconnected.
2. Select a location for the unit. An ideal installation location has the following characteristics:
 - Close to the battery (not in the same enclosure)
 - Protected from the weather
 - Well ventilated

Air enters by the fan at the rear of the unit, and exits through the sides of the unit.
For maximum unit performance, avoid recirculating the same hot air through the unit.

3. Route DC input cables.
Route the negative and positive DC input cables from the inverter (through the quick connector) to the battery. If required, protect cables where they contact hard, sharp edges.

DC Cable Length	
Size (AWG)	Maximum Distance (FT)
2 AWG	12ft
1/0	20ft

4. Install inline fuse.
Install an inline fuse in the red, positive DC input cable between the battery and inverter, **within 18 in. of the battery or DC wiring bus system.**

Vanner recommends using
Bussmann ANN-150 Fuse and #4164 Fuse Holder (Vanner P/N: 014838 Fuse and 03637 Holder) or
Feraz-Shawmut CNN-150 Fuse and #4164 Fuse Holder.
5. Connect bonding lug.
Use an 8AWG or larger copper conductor to connect the chassis bonding lug to the vehicle chassis.
6. Connect the inverter to the battery.
Connect the black, negative DC input cable from the quick connector to the battery negative (-) terminal. This battery negative terminal is usually where the battery negative connects to the engine block or frame. Connect the red, positive DC input cable from the quick connector to the in/line fuse near the battery positive (+) terminal. This battery terminal is usually connected to the DC electrical system at the battery side of the Battery Disconnect Switch.
7. Connect DC Power Source terminal to DC loads
Connect the output from the DC Power terminal on the front panel of the Inverter to equipment locations on the vehicle, 20A dc max. Max wire size is 12AWG, use the supplied "Vanner" screwdriver for this terminal.
8. Select Load Demand option.
Select Load Demand option if desired, using the proper switch position on the front panel Setup Switch. With Load demand ON, the inverter conserves battery energy and operates only when a load greater than 20 Watts is applied. (Factory setting is OFF).

9. Select battery type.
The charger is capable of charging both gel and flooded lead acid batteries. Select the battery type using the Setup Switch on the front panel. (Factory setting is Flooded).
10. Select the charging rate. (20-1050CUL-DC only)
In the high position, the output capability is 55 Amps. In the low position, it is 15 Amps. Vanner recommends the high position for all installations. The low charge rate can be used if there are NO additional DC loads on the vehicle. (Factory setting is 55A)
11. Select remote control style(s) being used. Either one, both or neither may be used.

To activate +12v remote control set the dip switch labeled IGNITION to the ON position. Connect the +12v remote control signal wire to the compression terminal labeled IGNITION.

To activate GROUND control set the dip switch labeled REMOTE to the ON position. Connect the GROUND control signal wire to the compression terminal labeled REMOTE.

If no remote control is required set both dip switches to the OFF position.

The compression connector is designed to accept bare copper wire, 28 – 12 gauge, stranded or solid. Each of the three positions consists of an upper actuator cavity and a lower spring-loaded wire clamp cavity. Insert the tool provided with the CUL-DC, or a small flat screwdriver, into the upper area of the actuator cavity. Gently lift the screwdriver handle UP which will open the spring-loaded clamp below. Insert the bare wire into the upper area of the clamp cavity.
12. Connect the AC loads.
Connect the AC loads to the inverter GFCI receptacle. Any time AC power is applied to the AC input (shore/utility power), it will pass through this GFCI receptacle.
13. Verify installation.
Verify all connections are tight and secure.

Inverter Lamp Description

Inverter	Light Action	Description
	Steady Green Light	Inverter in On and Operating.
	Single Blink Green Light	Inverter circuit is in Stand-by, Shore power is On and supplying AC power to the AC loads. The Inverter will turn On and supply the load if shore power is lost.
	Double Blink Green Light	Inverter circuit is in load Demand. Shore power is Off. The inverter is waiting for a load greater than 20 watts.
Battery Low	Light Action	Description
	Solid Red	Inverter is On and the battery is almost too low to operate the inverter.
	Blinking Red	The inverter is Off. The battery voltage dropped below 10.5 volts DC and the inverter shut itself Off. The inverter On/Off switch must be cycled to reset the unit.
Overtemp	Light Action	Description
	Solid Red	The unit is Off. The unit has turned itself Off because it is too hot. This can be caused by operating an AC load which is too large for the inverter, or lack of ventilation. When the unit cools the inverter will start operating again.
Overload	Light Action	Description
	Blinking Red	The inverter is On but overloaded. Reduce the AC load quickly or the inverter will shut off due to the overload condition.
	Solid Red	The inverter is Off. An overload has occurred and the inverter has shut off to protect itself. Reduce the AC load, the inverter On/Off switch must be cycled to reset the unit.
Charger Bulk Absorption	Light Action	Description
	Blinking Yellow	The charger is operating. The batteries were low and in need of a charge. The charger is in the process of charging the batteries to the bulk voltage. The charging current is limited based on the position of the Charger High/Low switch.
Charger Ready/Maint.	Light Action	Description
	Solid Green	The charger is operating. The batteries are near full charge and the charger is in the maintenance mode. In this stage, the charger is holding the batteries at the float voltage. The charging current is limited based on the position of the Charger High/Low switch.

Section 6: Installing the Inverter and Charger Remote Status Display Panels

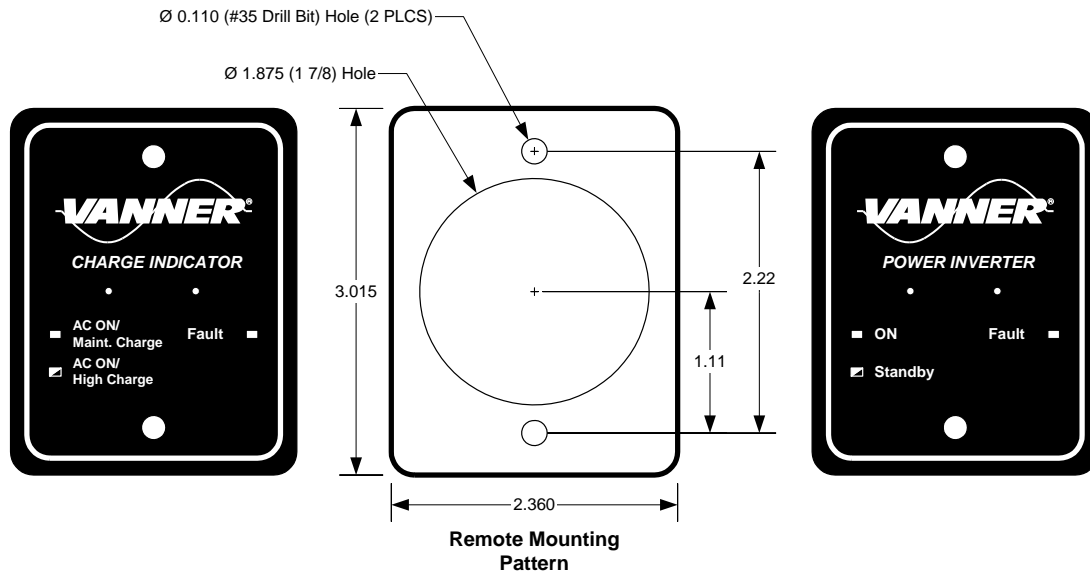

There are two remotes available for the 20-1050CUL-DC, One for Inverter Status (Part Number – **LSIR**) and the other is for Charger Status (Part Number – **LSCR**). Both the Inverter and Charger Remote Status Display Panels contain a red and green LED indicator, On the charger status panel, a SOLID green light indicates the presence of shore power or that the battery is being maintained at its current level. A FLASHING green light indicates the presence of shore power and the charger is in high charge mode. On the inverter status panel, the SOLID green indicator light signifies the unit is ON, a FLASHING light indicates the unit is in the Standby mode. For both the remotes the red Fault LED indicator shows problems such as over temperature, output overload, or low battery.

The panels have a gasket seal which will keep the electronics safe from weather and water spray. Each panel is equipped with a RJ45 connector for easy installation and replacement. The following installation procedure applies to both the inverter and charger panels:

Step 1: Select a location for the panel.
Identify the desired location for the inverter and/or charger panels.

Step 2: Route cable.
Carefully route the modular cable from the front of the LifeStar to the remote location. This cable does not need to be shielded but it should be routed away from the AC cables.

Step 3: Secure panel to surface.
Remove the protective liner from the gasket and mount the panel using the provided #8 screws through the two holes in the panel.

Section 7: Operating the 20-1050CUL-DC Ambulance Power Module

Use the following instructions to operate the 20-1050CUL-DC Inverter.

Step 1: Install the 20-1050CUL-DC Unit.

Completely install the inverter and charger using the instructions provided in Section 2 of this manual.

Step 2: Start the vehicle.

Step 3: Turn switches on.

Turn on the Module Disconnect Switch and the Inverter Remote Switch.

Step 4: Verify Power.

Apply an AC load, such as a shop light or drill. Verify operation.

Step 5: Apply shore power

Turn vehicle off, apply shore power to the 20-1050CUL-DC/Ambulance shore line connection. After shore power has been connected one of the Chargers LED's will light or flash. Push the ON-OFF/RESET Inverter Switch to the ON position. The inverter lamp will flash, indicating that the inverter is standing by.

Step 6: Observe Transfer Switch.

Remove the shore line connection from the emergency vehicle. The unit will automatically switch to Inverter mode and operate the AC load using battery power. When shore power is restored, the unit examines the AC input for five seconds and then switches the loads back to run directly from AC shore power.

Section 8: Troubleshooting the 20-1050CUL-DC

The following are the most common questions heard by Vanner service professionals. If your situation does not apply to the following categories, please contact your local Vanner Inc Distributor.

Vanner Inc Customer Service: 1-800-AC-POWER

- SYMPTOM** All of the LED's on the front panel blink one at a time, in sequence.
- SOLUTION** It is normal for this to occur if the inverter switch is On when the DC input is connected to the unit. If the DC is already connected and the LED's blink in sequence then the DC input is dipping in voltage.
- Check for poor connections in the DC wiring, bad battery, or a heavy DC load.
- SYMPTOM** ON lamp flashes or does not light steadily after pushing in the ON-OFF/RESET Inverter Switch.
- SOLUTION** Lamp flashes when utility power is present. Lamp flashes in Load Demand Waiting mode. Check/Reset GFCI on the receptacle. See * Note on page 6.
Check battery connections if utility power is OFF
Check DC fuses if utility power is OFF
- SYMPTOM** ON lamp fully illuminates. AC load does not run.
- SOLUTION** Check and reset circuit breaker.
Check and reset GFCI. See * Note on page 6.
Verify AC load and cord is in proper condition.
- SYMPTOM** BATTERY LOW lamp illuminates when AC load is applied.
- SOLUTION** Check battery connections.
Check battery condition.
Recharge battery if voltage is less than 10.5 VDC.
Check the vehicle's alternator charging system for proper operation.
- SYMPTOM** OVERTEMP lamp illuminates.
- SOLUTION** Something has caused the unit to overheat. Check for obstruction of air flow to the cooling fan or from ventilation holes. Verify AC load is within unit's rated capacity.
- SYMPTOM** OVERLOAD lamp illuminates with AC load applied.
- SOLUTION** Verify AC load is within unit's rated surge and continuous capacity.
- SYMPTOM** DC fuse blows when connecting DC input cables.
- SOLUTION** Check for reverse polarity: red cable to battery positive (+), black cable to battery negative (-). The unit may be damaged and require repair service.
- SYMPTOM** Low battery lamp glows dimly when inverter is off.
- SOLUTION** This is normal.

Notes:

**Vanner Incorporated
4282 Reynolds Drive
Hilliard, Ohio 43026**

**1-800-AC POWER
(1-800-227-6937)
Tel: 614-771-2718
Fax: 614-771-4904**

**www.vanner.com
e-mail: pwrsales@vanner.com**

**Part Number D914588-H
8-4-2017 Printed in U.S.A.**