

High Voltage Distribution Module

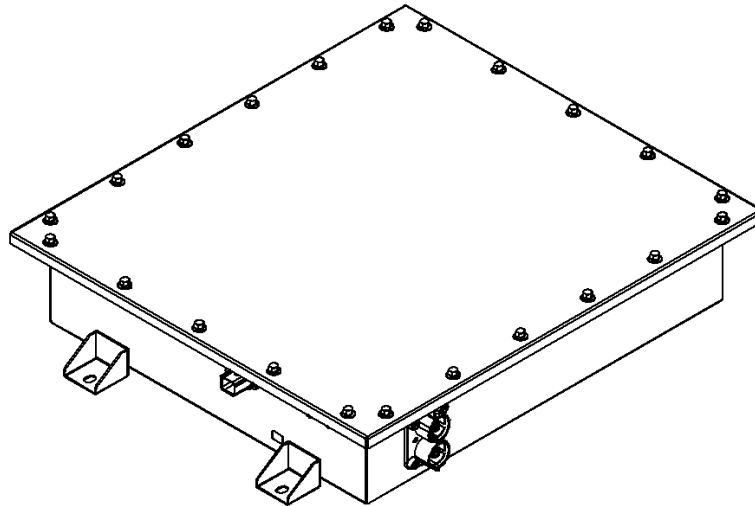
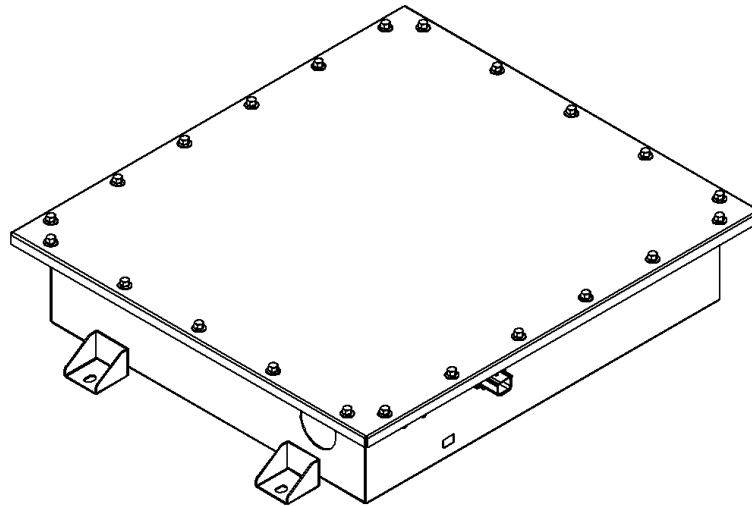

Table of Contents

Introduction.....	3
Operational Specifications.....	4
Dimensional and Mounting Specifications.....	5
Discrete and HVIL I/O Specifications.....	7
CAN and I/O Definitions.....	9
Power Wiring Input/Output Specifications.....	10
Operation.....	14
Installation Instructions.....	17
Typical Application.....	19
Testing and Troubleshooting.....	21
CAN Messages Specification.....	26

Notes

Introduction

Thank you for purchasing Vanner's *High Voltage Distribution Module*. We are confident that you will be very pleased with its performance since Vanner products are designed and manufactured by skilled professionals using the highest standards in workmanship. With minimum maintenance and care, you can be assured of many years of trouble-free service.

General Description

The Vanner *High Voltage Distribution Module* (commonly referred to as HVDM in this document) is an efficient and highly reliable method of distributing high voltage, 400 to 800VDC, derived from a traction battery system. The high voltage is distributed to two fused output channels via high voltage contactors.

The HVDM is also provisioned with pre-charge circuitry for each output channel. Pre-charge circuitry and contactor closing/opening is controlled independently for each channel to allow for connecting and disconnecting the individual loads.

The HVDM is controllable over a J1939 CAN (Controller Area Network) with additional discrete controls. It will also monitor and control the two output channels and report their status over a J1939 CAN network.

The HVDM is provisioned with a two-pin sealed connector for integration into the vehicle's high voltage interlock system and a twelve-pin sealed rectangular connector for CAN and discrete I/O signals.

Operational Specifications

High Voltage Distribution Module		
IAP2 Model Numbers (250kbps)	HVDM-C135A-C280A	HVDM-C150A-C280A HVDM-C150A-C280A-C3
IAP2 Model Numbers (500kbps)	HVDM-5-C135A-C280A	HVDM-5-C150A-C280A HVDM-5-C150A-C280A-C3
IAP2 Fuse Ratings (See notes below table.)	CH1 - 35A CH2 - 80A	CH1 - 50A CH2 - 80A
IAP2 Model Number (500kbps/3 rd Fuse)	-	HVDM-5-50-80-50
IAP2 Fuse Ratings (3 rd Fuse)	-	CH1 – 50A CH2 – 80A CH2.1 – 50A
eGen Flex Model Number (500kbps)	HVDM-5-C150A-C280A-EGF (Fusing is same as HVDM-5-C150A-C280A)	
High Input Voltage Range (VDC)	400 – 800	
High Input Voltage Nominal (VDC)	550 - 700	
High Input Voltage Max Survivable (VDC)	1,200	
Low Input Voltage Range (VDC)	18 - 32	
Max Continuous Current (AMPS)	60A/Channel Note: The HVDM hardware can support 60A/Channel, however, it is limited by the exportable power rating of the hybrid traction drive system.	
Max Pre-Charge Current (AMPS)	10	
Max Capacitive Load (µF)	6,800	
+24V Battery Input Current (AMPS)	< 200mA	
Ignition Input Current (AMPS)	+24V < 5mA +12V < 10mA	
Cooling Method	Passive Convection	
High Voltage Passive Discharge	Upon opening of contactors, removal of high voltage or terminal access cover, a capacitive load of 3,400µF will discharge to 50 VDC or less within 5 minutes. A capacitive load of 6,800µF will discharge to 50 VDC or less within 10 minutes.	
Ambient Operating Temperatures	Min: -40°C (-40°F) Max: 70°C (158°F)	
Storage Temperature	-40°C to +105°C (-40°F to 221°F)	
Serviceable	Internal components to be serviced by Vanner personnel only. No routine maintenance of module is required. Note: In the event an internal fuse is blown, it may be replaced by a qualified technician. Care must be taken in following high voltage safety procedures prior to servicing and tightening hardware to specified torque values.	
Environmental Considerations IP55 Rated	Powder coated galvanized steel enclosure provides protection against salt, fungus, dust, water, fuel vapors and all fluids associated with commercial and off-highway vehicle operations.	
Mounting Location	Mount on a flat surface (horizontal or vertical orientation) close to the high voltage batteries to permit short cable runs.	
Weight (lbs.)	30 (13.6kg)	

Notes:

1. **Channel 1 output is reserved for Vanner HBA's.** Performance of the HVDM will be compromised if the load connected to Channel 1 is not single or dual HBA's.
2. Channel 1 output is fused at 50A for Dual HBA's used in IAP2 applications.
3. Channel 2 output is fused at 80A for the VEPI (Vanner Exportable Power Inverter) used in IAP2 applications.
4. Channel 2B is fused at 50A for high voltage DC accessories.

Dimensional Specifications

(All Dimensions are in Inches and Apply to all HVDM Model Numbers)

Cover attached with 22-M6 x 12mm flanged hex head cap screws.

Tighten to a torque value of 75lb-in (8.5N-m)

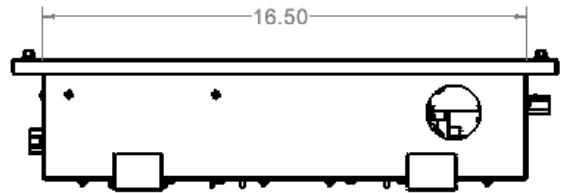
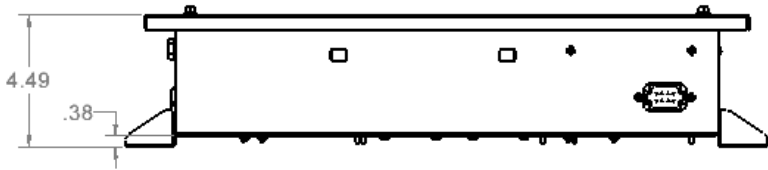
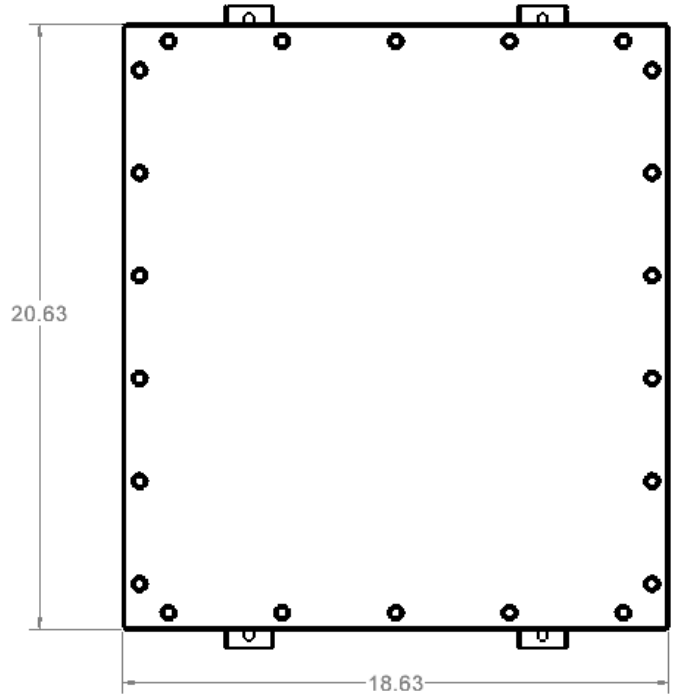

Mounting Specifications

(All Dimensions are in Inches and Apply to all HVDM Model Numbers)

.344 X .500, TYP

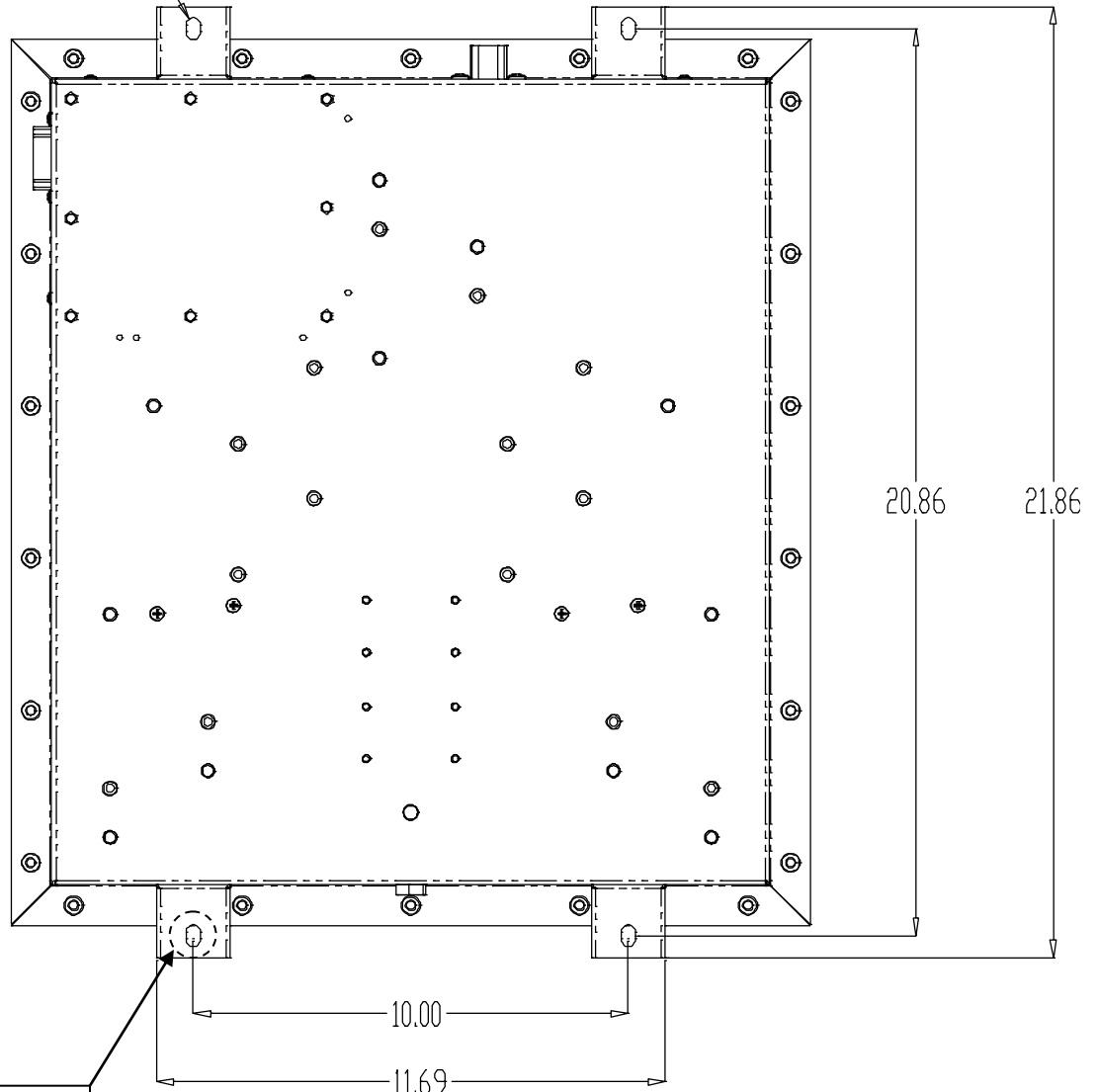

1" Dia. masked area on
topside of mounting foot to
ground chassis to bus
frame. (CH1 Exit)

Discrete and HVIL Input/Output Specifications

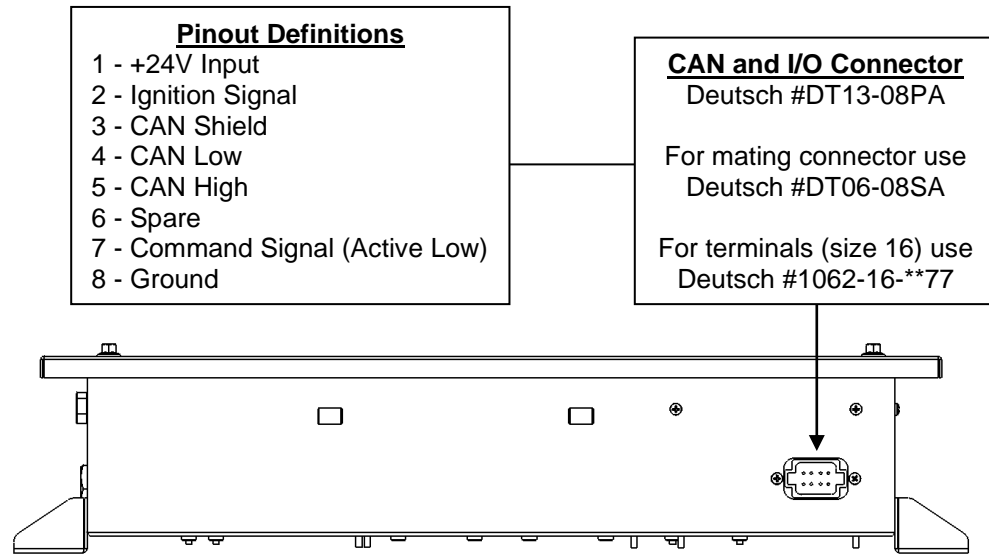

View of IAP2 Version of HVDM

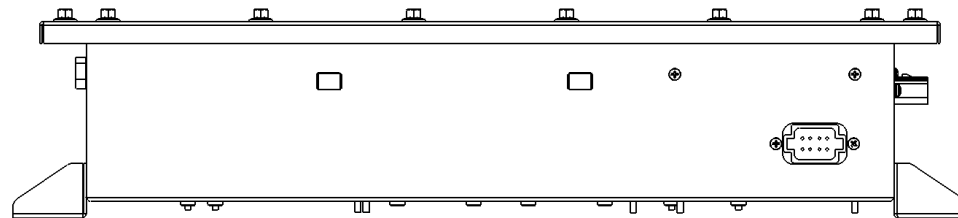

View of eGen Flex Version of HVDM

Note: Deutsch part number suffix (**) is dependent on wire gage and insulation diameter.

Discrete and HVIL Input/Output Specifications Cont'd

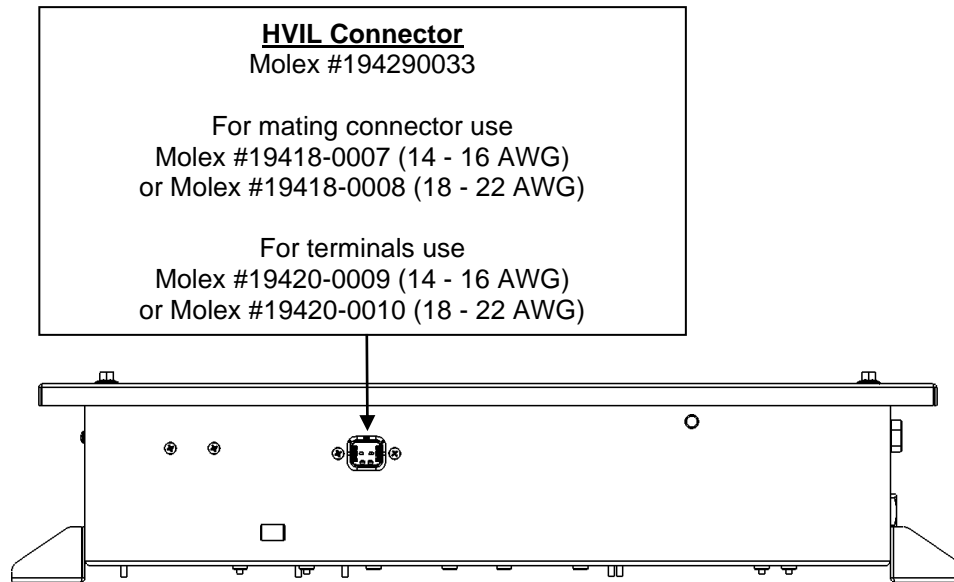

View of IAP2 Version of HVDM

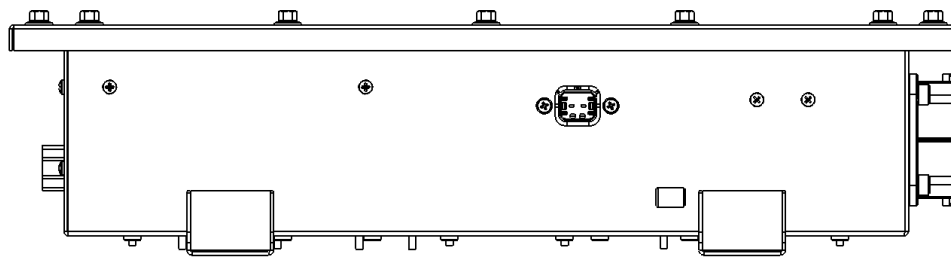

View of eGen Flex Version of HVDM

CAN and I/O Definitions and Functionality

1. **+24V Input**
The +24V input powers the HVDM control board. The input shall come from the most convenient termination point that is on the secondary side of the house battery main disconnect switch.
2. **Ignition Signal**
The ignition signal "wakes" the HVDM up. It may be +12V or +24V.
3. **CAN Shield**
This connection is used to make the shield on the CAN cable common. This is required for electrical noise considerations in vehicle electrical systems.
4. **CAN Low**
This is the low signal connection for the vehicle's CAN bus. The HVDM will communicate faults to the vehicle's electrical system controller via the CAN bus.
5. **CAN High**
This is the high signal connection for the vehicle's CAN bus. The HVDM will communicate faults to the vehicle's electrical system controller via the CAN bus.
6. **Spare**
7. **Command/Hardware Enable Signal**
This is an active low signal that comes from the TCM (Transmission Control Module) of the hybrid drive system. Reference Allison Transmission's Technical Document 192 for circuit requirements for this input.
8. **Ground**
The ground input powers the HVDM control board. The input shall come from the most convenient termination point tied to battery negative. Do not terminate to vehicle chassis.

Power Wiring Input/Output Specifications

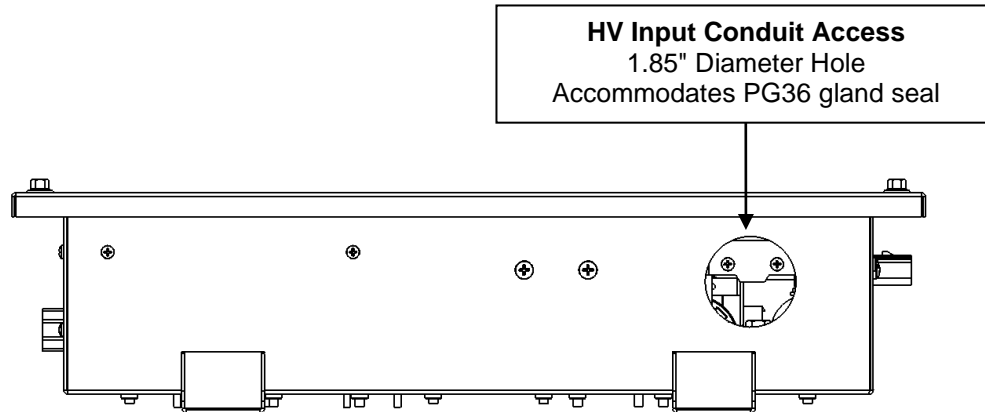

View of IAP2 Version of HVDM

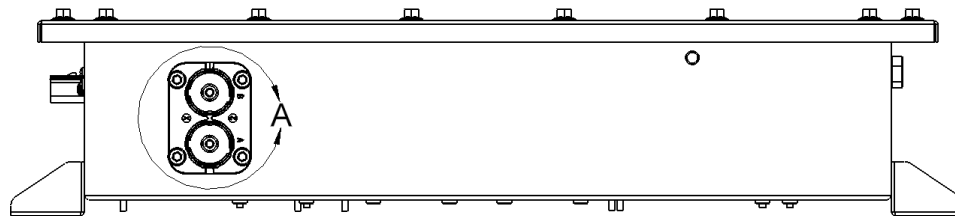

View of eGen Flex Version of HVDM

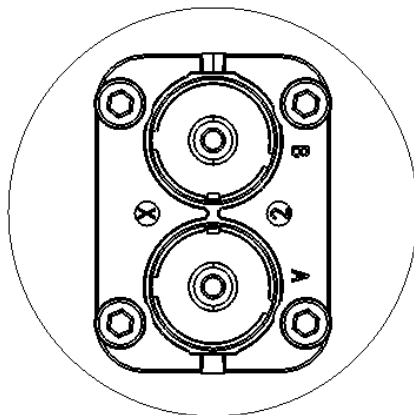

Detail A

Power Wiring Input/Output Specifications Cont'd

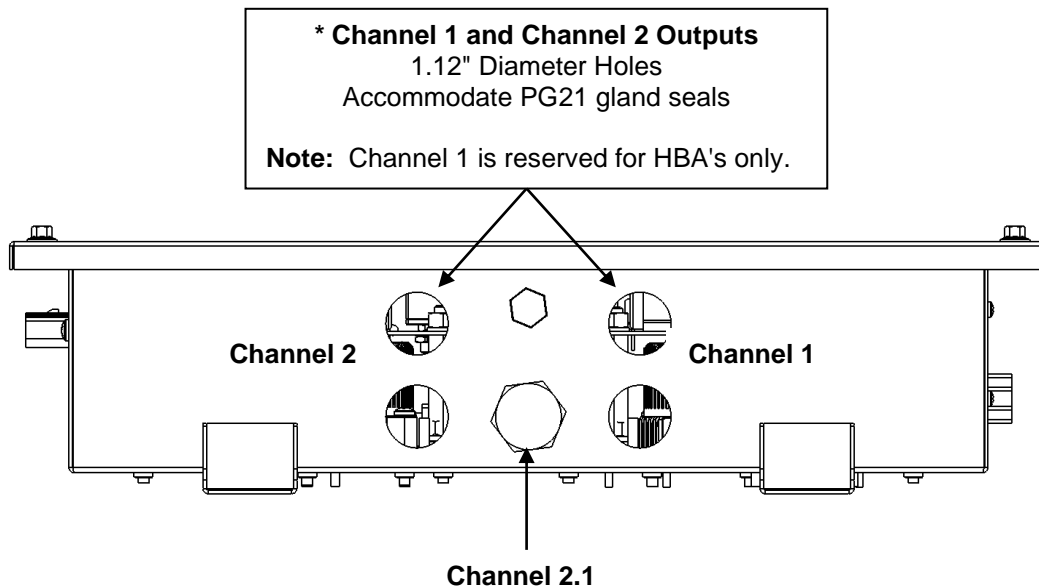

* The HVDM is provisioned with two gland seal holes for Channel 1 and three gland seal holes for Channel 2. The Channel 1 access points are for HBA's only in IAPI or IAP2 applications. The Channel 2 access points are for pre-approved high voltage DC loads such as Vanner's Exportable Power Inverter (VEPI) and miscellaneous high voltage DC loads.

Two studs per pole/channel are also provided to prevent installing two lugs on one stud.

EMI blanking plugs will be installed in any unused gland seal holes at the factory.

Power Wiring Input/Output Specifications Cont'd

Positive Terminals and Fuse Terminals

The positive and fuse terminals are M8 x 1.25 studs
Tighten to a torque value of 100 lb-in (11 Nm)

Negative Terminals

The negative terminals are M10 x 1.5 studs
Tighten to a torque value of 150 lb-in (17 Nm)

Internal View of IAP2 Version of HVDM

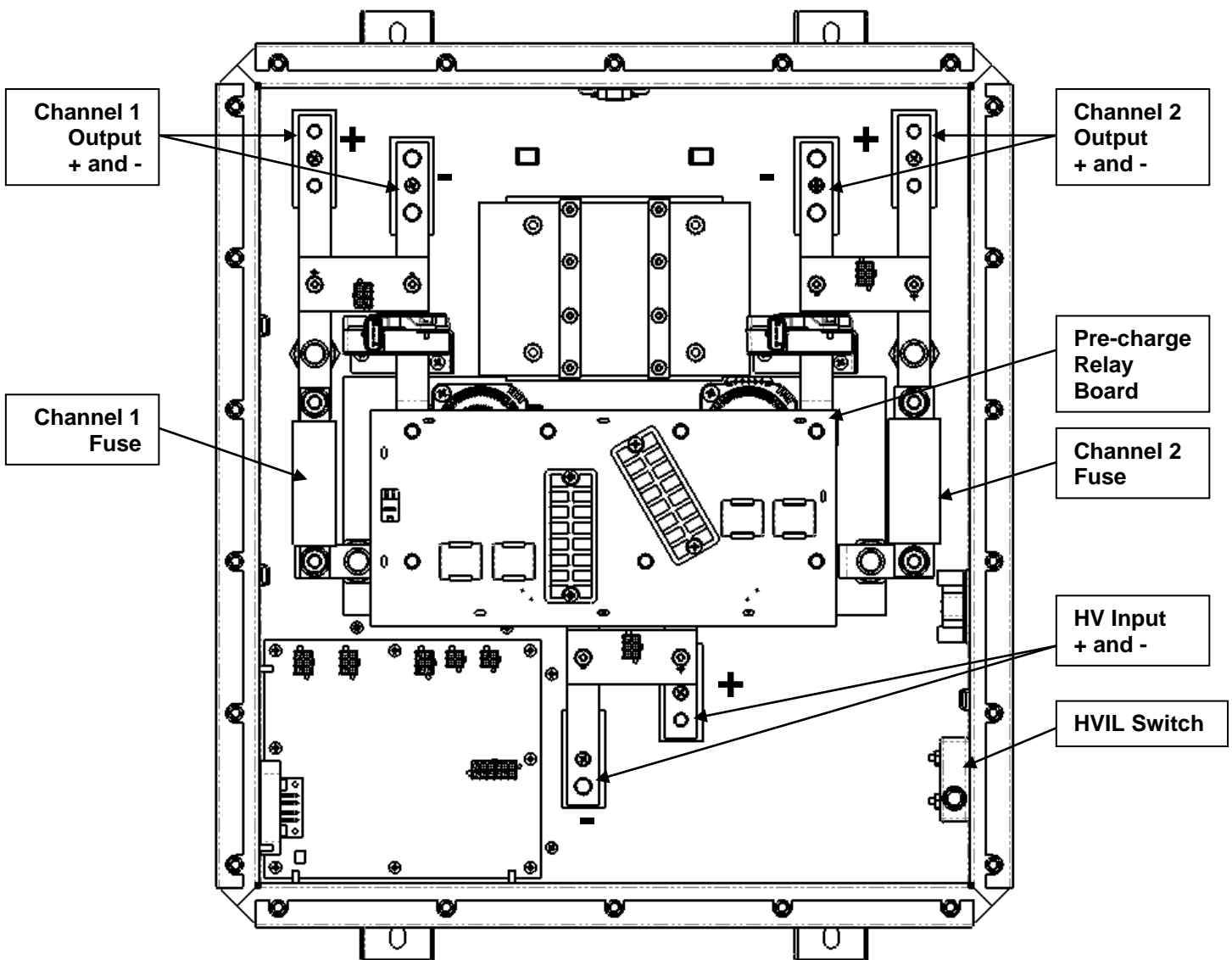

Power Wiring Input/Output Specifications Cont'd

Internal View of eGen Flex Version of HVDM

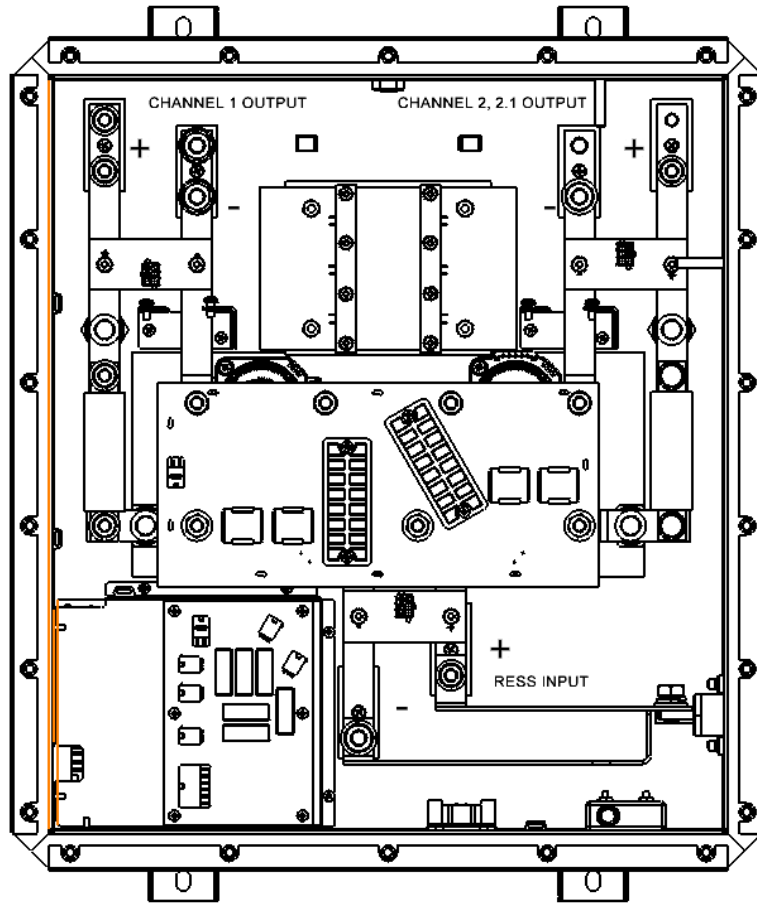

Internal View of Three Fuse Version of HVDM

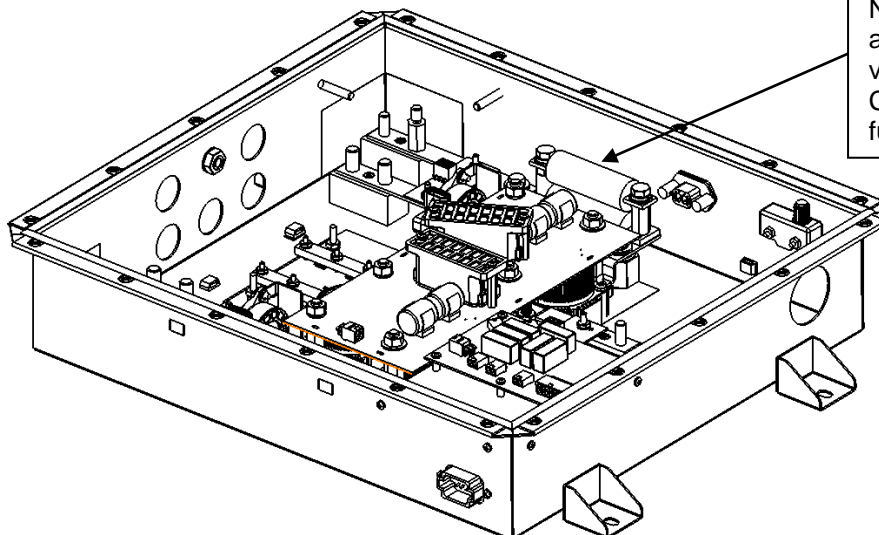

Note third fuse for additional high voltage DC load on Channel 2. Bottom fuse is for VEPI.

Operation

Distribution Module Start Up/Normal Operation

The following outlines the sequence of events that permit contact closure to power loads connected to Channels 1 and 2 under normal conditions.

Standby Mode

1. HVDM is in "Standby" mode while awaiting +24V and ignition inputs from vehicle.

Controller Power Up

2. After receiving an ignition signal and +24V inputs, the HVDM controller will power up and perform a low voltage self test.
 - Note: the low voltage must be between 18 - 32VDC.

Ready State

3. After successful completion of power up and low voltage self test, the HVDM will enter a "Ready" state.
4. After entering the "Ready" state, the HVDM will wait for a hardware enable command, active low, from the TCM.
5. After receiving the hardware enable signal, the HVDM will perform a high voltage self test.
 - Note: the high voltage must be between 400 - 800VDC.
6. After successfully completing the high voltage self test, the HVDM will wait for a CAN message from the hybrid controller to proceed with pre-charging the connected load(s).

Contact Closure

7. Upon successful completion of pre-charging the load(s), contact closure will occur. The load(s) are now connected to the high voltage battery/traction system.
 - The HVDM is designed to pre-charge a maximum capacitive load of 6,800 μ F in 2.5S.
8. After contact closure, the HVDM enters a "Contactor Closed" state.

Contact Opening

9. The contactors are opened via CAN message or removal of the hardware enable signal.
10. The passive discharge board will discharge the capacitive load(s) after contactor opening.

Operation Cont'd

Distribution Module Abnormal Conditions

The following outlines conditions that will flag faults and the resultant impact on contactor closure/opening. All conditions apply to both Channels 1 and 2. Reference Vanner's "High Voltage Distribution Module DM1 Messages CAN Communication Specification" for more details about DM1 messaging.

Over Capacitance

- If pre-charge fails within 1 second due to a load capacitance $\geq 6,800\mu\text{F}$, a fault will be flagged during the current key cycle. The fault will clear upon cycling the 24V off/on.

Short Circuit

- If pre-charge fails within 100 milliseconds, a fault will be flagged during the current key cycle. The fault will clear upon cycling the 24V off/on.

Welded Contactor

- The HVDM is provisioned with welded contactor detection circuitry. If the HVDM detects one or more welded contactors on the respective channel, the channel is disconnected for the current key cycle.

Pre-Charge Lockout

- If pre-charging load(s) is unsuccessful after 2 attempts, the channel will be disconnected from the high voltage bus during the current key-cycle.

Non-Operational Relay

- If the HVDM detects a non-operational relay, a fault will be flagged during the current key cycle. The fault will clear upon cycling the 24V off/on.

High Voltage Out of Range (340 - 860VDC)

- If the HVDM detects the high voltage is out of range, a fault is flagged.
- High: If channel is not connected, it will not connect upon receiving turn-on command; If channel is already connected, it will remain connected. The fault will clear when the input voltage drops below 850V.
- Low: If channel is not connected, it will not connect upon receiving turn-on command; If channel is already connected, it will remain connected. The fault will clear when the input voltage rises above 350V.

+24VDC Out of Range (18 - 32VDC)

- If the HVDM detects the low input control voltage is out of range, a fault is flagged.
- High: If channel is not connected, it will connect upon receiving turn-on command; If channel is already connected, it will remain connected. The fault will clear when the input voltage drops below 30.5V.
- Low: If channel is not connected, it will connect upon receiving turn-on command; If channel is already connected, it will remain connected. The fault will clear when the input voltage rises above 19.5V.

Over Current ($\geq 160\text{A}$)

- If an over current condition exists, a fault is flagged, and the contactors opened during the current key cycle. The fault will clear upon cycling the 24V off/on.

Distribution Module Abnormal Conditions Cont'd**Temperature Out of Range (Loose Connection Detection)**

- The HVDM is provisioned with temperature sensors on the HV Input bus bars as well as Channel 1 and Channel 2 output bus bars for the purpose of detecting loose mechanical connections. If the HVDM detects an over-temperature condition (+95°C), a fault is flagged and both channels are disconnected for the current key cycle.

Current Sensor Data Erratic

- The HVDM is provisioned with automotive style sensors for measuring current on both output channels. If the signal voltage from a sensor to the control board falls outside of the 2.5V - 5V range, a fault will be flagged. If channel is not connected, it will connect upon receiving turn-on command; If channel is already connected, it will remain connected. The fault will clear when the signal voltage falls within the 2.5V - 5V range.

Loss of CAN Command

- If the HVDM loses the CAN turn on command from the HCM (Hybrid Control Module), a fault is flagged. If channel is not connected, it will connect upon receiving turn-on command; If channel is already connected, it will remain connected. The fault will clear when new CAN command is received continuously.

Installation Instructions

These symbols are used to note procedures that if not closely followed could lead to loss of life or damage to equipment or property due to electrocution.



Electrocution hazard exists



Fire hazard exists



A potentially dangerous condition



Explosive hazard exists



Corrosive hazard exists



Do not exceed the specified torque value of 100 lb-in (11Nm) when connecting cables to the **positive** (+600V) input and output studs during installation of the HVDM. Torque values higher than specified may damage the product, reduce performance, and/or create hazardous conditions. Products damaged by improper torque are not covered by the warranty.



Do not exceed the specified torque value of 150 lb-in (17Nm) when connecting cables to the **negative** input and output terminal posts (-600V) during installation of the HVDM. Torque values higher than specified may damage the product, reduce performance, and/or create hazardous conditions. Products damaged by improper torque are not covered by the warranty.



Do not connect more than one conductor per terminal post on Vanner HVDM. Multiple wires and cables may overstress internal components, resulting in poor performance or creating hazardous conditions. Products damaged by the installation of multiple conductors per post are not covered by the warranty.



Caution: This equipment contains components that may produce arcs/sparks during a fault condition. To prevent fire or explosion, compartments containing batteries or flammable materials must be properly ventilated. Safety goggles should always be worn when working near batteries.



Mounting Location –The HVDM must be mounted on a flat horizontal or vertical surface suitable for support during application. Do not mount in a zero-clearance compartment that may result in overheating. Locate the HVDM so that contact by unauthorized personnel is unlikely.

Installation Instructions Cont'd

Environmental Protection

Your HVDM has been designed to withstand intermittent exposure to rain, moisture and direct pressure spray. However, continual exposure to rain and/or direct pressure spray may reduce the serviceable life of the unit. Any damage due to water contamination is covered by Vanner only through the terms of the factory warranty.



Wiring

After mounting the HVDM as outlined above, the shielded high voltage input and Channel 1/Channel 2 output wires may be installed. Reference the "Wiring Input/Output Definitions" section of this manual for proper identification/location of the input and output studs.

Note: The HVDM positive and negative studs are staggered and are different sizes to minimize the risk of reverse polarity connections.

Ensure proper clearances are provided when routing wires within the HVDM enclosure to eliminate the risk of chafing/abrading the insulation. If proper clearances aren't provided, a short circuit could occur causing severe damage.

The I/O and HVIL wiring may be installed upon completion of installing the high voltage wiring. Reference the "Wiring Input/Output Definitions" section of this manual for proper identification of the pinouts for the I/O and HVIL connectors.



Wire Sizes

The shielded cables connecting the HVDM to the hybrid traction battery shall be appropriately sized based on the current limiting device between the input and battery.

The shielded cables connecting Channel 1 and Channel 2 outputs to their respective loads shall be appropriately sized based on the factory installed fuses. 8 AWG wire is recommended as a minimum for 35A and 50A fuses. 4 AWG wire is recommended as a minimum for an 80A fuse.

Note: The above wire sizes are for recommendation only. Wire sizing charts should be consulted by the installer to ensure voltage drop and temperature de-rating factors are taken into consideration.

Typical IAPI Diagram for Transit Bus

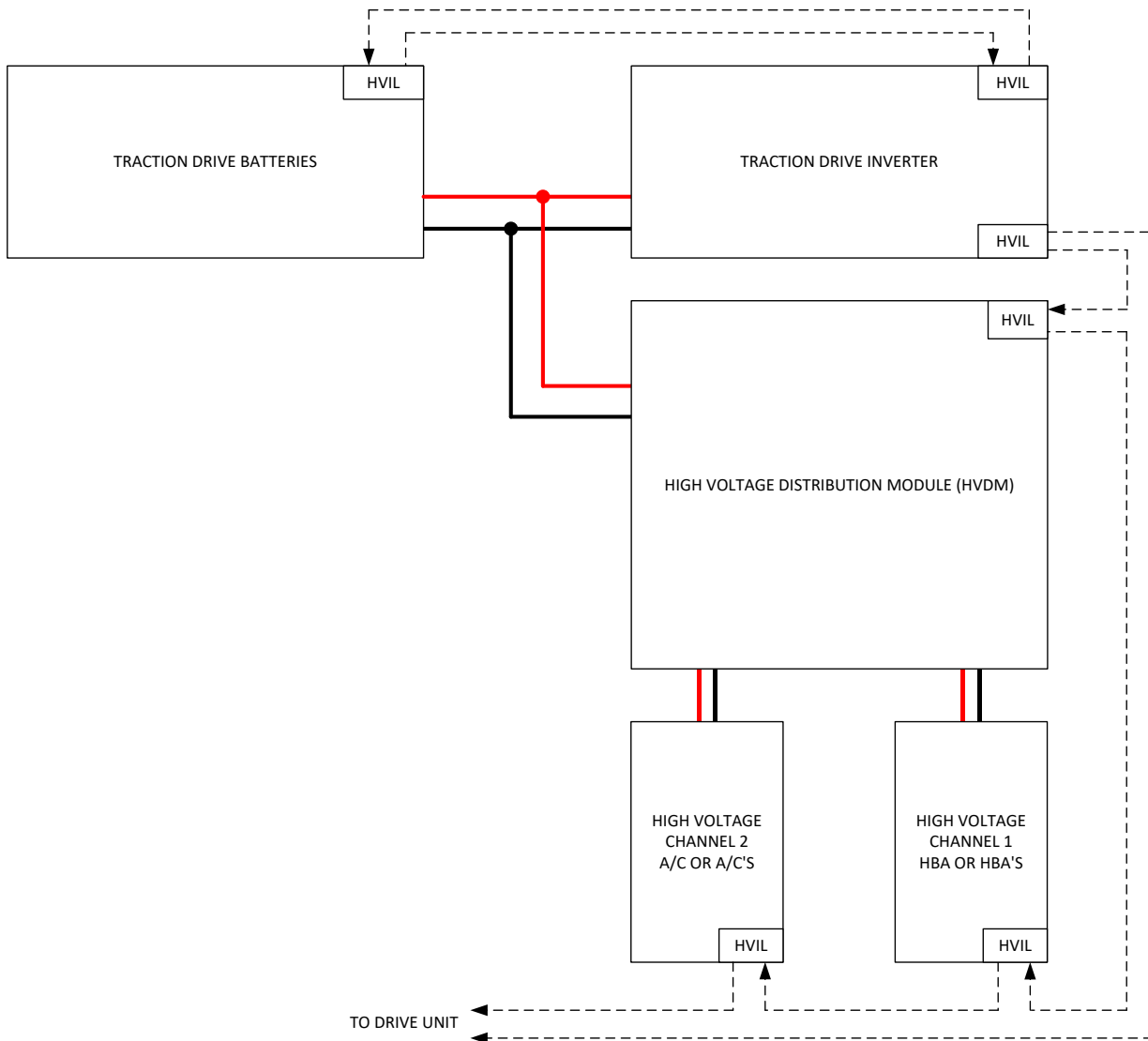

Note: This is a basic block diagram of the major components and HVIL circuit comprising an IAPI system and is for reference only. Refer to Allison Transmission's technical documentation for detailed requirements of HVIL wiring.

Typical IAP2 Diagram for Transit Bus

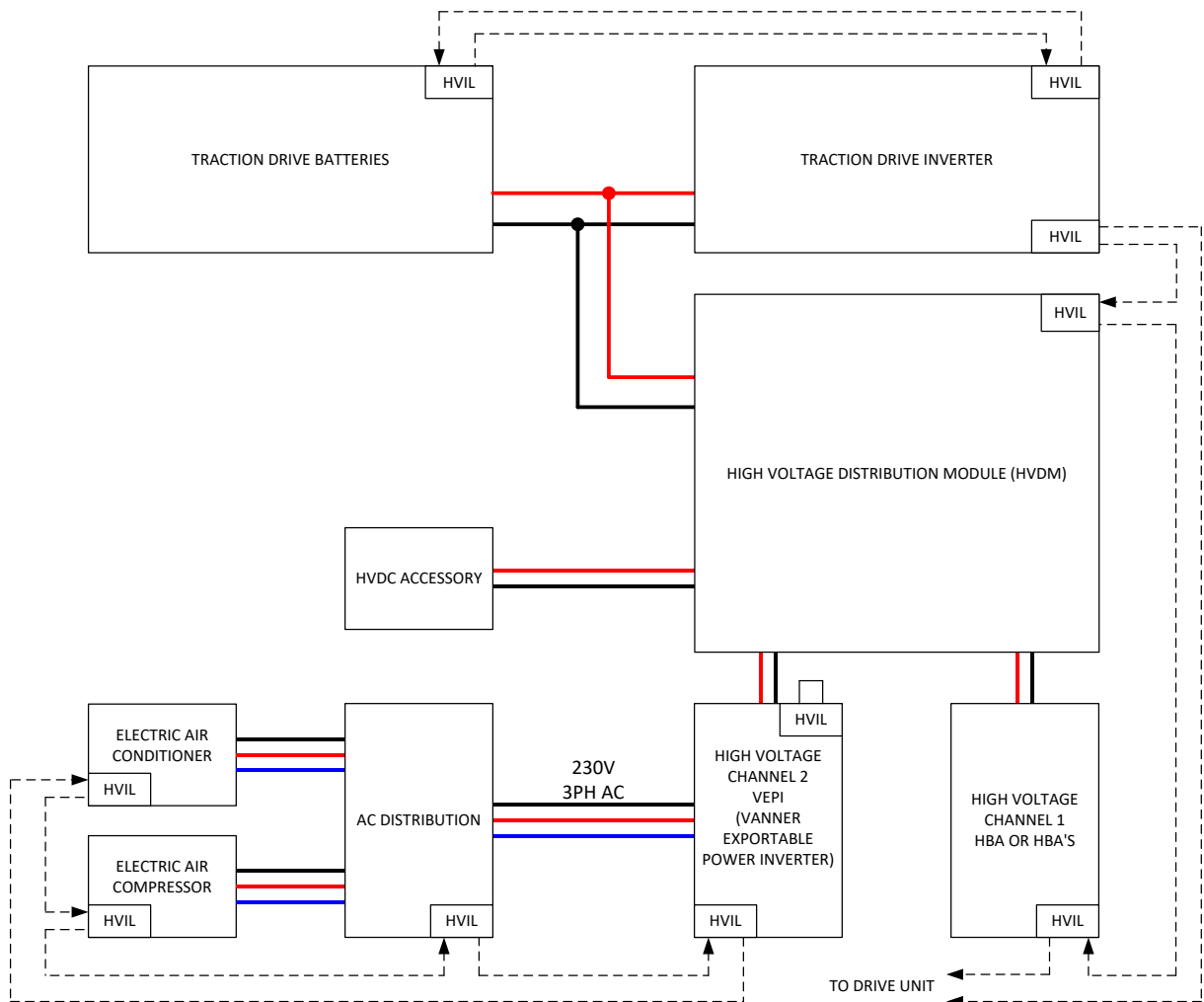

Note: This is a basic block diagram of the major components and HVIL circuit comprising an IAP2 system and is for reference only. Refer to Allison Transmission's technical documentation for detailed requirements of HVIL wiring.

Testing and Troubleshooting

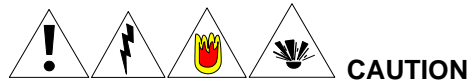

Servicing of electrical systems should only be performed by trained and qualified technical personnel.

Equipment Required

VoltMeter having 0.01-volt resolution. (Fluke Model 87 Multimeter recommended).

Clamp-on current meter (Fluke Model 36 Clamp-on Meter recommended).

Optional: Vanner laptop provisioned with Vanner Dashboard software
USB to CAN adapter module. (PEAK System's PCAN-USB IPEH-002021)

Note: There are kits available for purchase that include Vanner's Dashboard software, a USB to CAN adapter module and a harness to connect to the vehicle's CAN network. Please contact Vanner's inside sales department for the appropriate kit part number for your application.

Vanner Repair Service

Vanner offers a quick turn-around factory repair service. Send the unit to the address on last page with a note instructing us to repair it. Include your name, phone number, shipping address (not a P.O. Box Number), and your purchase order number.

Test Procedure for HVDM

HVDM Test Procedure:

Note: Although not required, using Vanner's Dashboard Interface software for monitoring the status of the HVDM is highly recommended. The Dashboard software provides a graphical representation of the states of the Channel 1 and 2 contactors as well as the high voltage and current of each channel.

1. Field-test the HVDM while fully connected to the vehicle's high voltage batteries and the Channel 1 and Channel 2 loads.
2. Ensure the chassis cover is installed and all fasteners are in place. The HVDM is provisioned with an HVIL switch, therefore if the cover is not installed properly, the ESS contactors will not close.
3. The low voltage battery must measure between 18 and 32 volts. If the low voltage battery is below 18 volts, apply a 24 volt battery charger to the batteries.
4. The high voltage battery must measure between 400 and 800 volts for the HVDM to start properly.
5. Monitor the HVDM status via laptop provisioned with the Dashboard software.
6. The HVDM will enter the "Standby" mode when the low voltage battery master disconnect switch is closed.
7. Start the vehicle normally.
8. Provided the operational conditions outlined above are met, the HVDM will enter a "Ready" state upon receiving an ignition signal and await a hardware "Enable" command, active low, from the TCM.
9. After receiving the "Enable" command from the TCM, the pre-charge sequence will begin once the HVDM receives a "Connect" CAN message from the HCM.
10. Upon successfully pre-charging the loads on Channel 1 and/or Channel 2, the respective contactor(s) will close.
11. The contactor status is graphically displayed on the Dashboard, but closure can also be verified by observing the voltage and current values. **Note:** The current and voltage values are measured on the secondary side of the contactors.
12. If the Dashboard software isn't being utilized, contact closure can be verified by observing the operational status of the loads connected to Channel 1 and/or Channel 2.
13. Upon successful contact closure, the HVDM enters an "Open Pending" state. The contactors are opened via the CAN "Disconnect" message or removal of the hardware enable signal.

Note: The high voltage terminals are inaccessible for measurement with a meter. A high voltage interlock circuit is implemented for safety purposes to prevent an accidental and potentially lethal shock to service personnel. The high voltage input and Channel 1 and Channel 2 outputs can only be read via the Dashboard software.

HVDM Dashboard Screenshots

Figure 1: HVDM in "Ready" state after receiving ignition signal

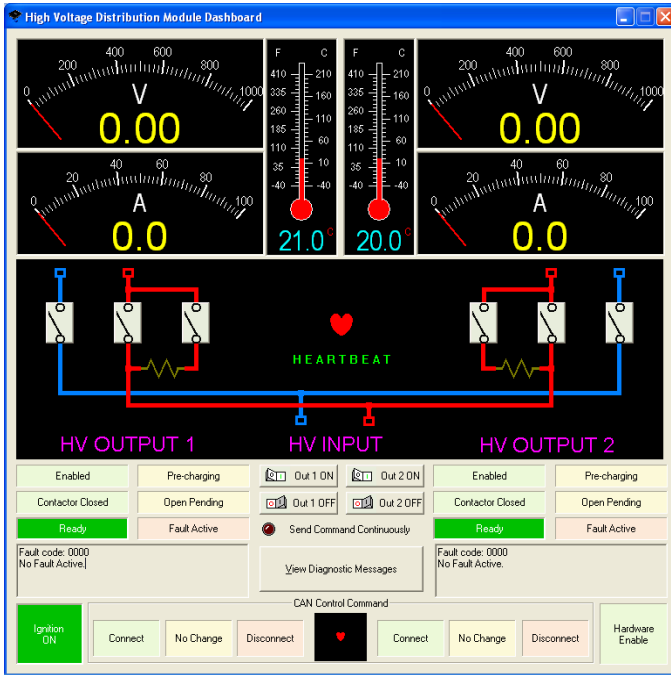

Channel 1 and Channel 2 voltages, currents and bus bar temperatures displayed in this section

Graphical representations of Channel 1 and Channel 2 contactor states in this section

HVDM and contactor status information displayed in this section

Ignition, enable and CAN Control Command information displayed in this section

Figure 2: Hardware "Enable" signal from TCM activated. Note contactors are still open.

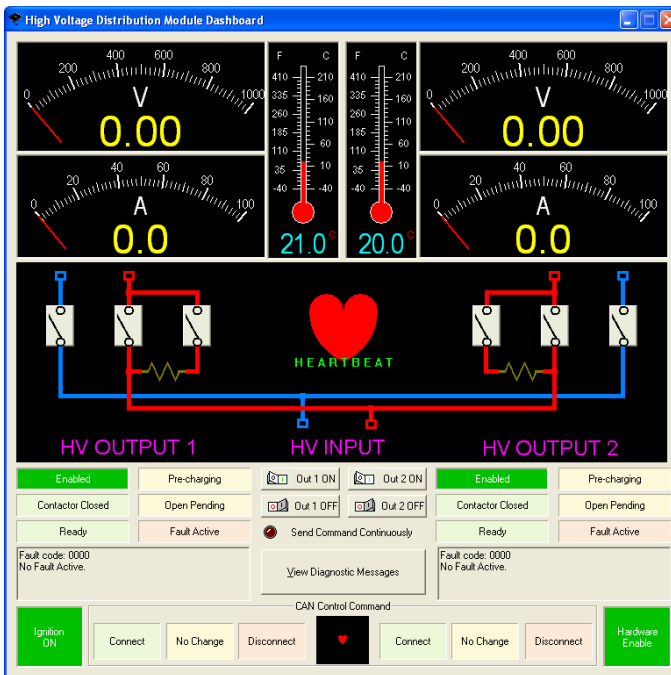

Note status change to "Enabled"

Note "Hardware Enable" icon is lit

Figure 3: Contactors closed after receiving CAN message from HCM

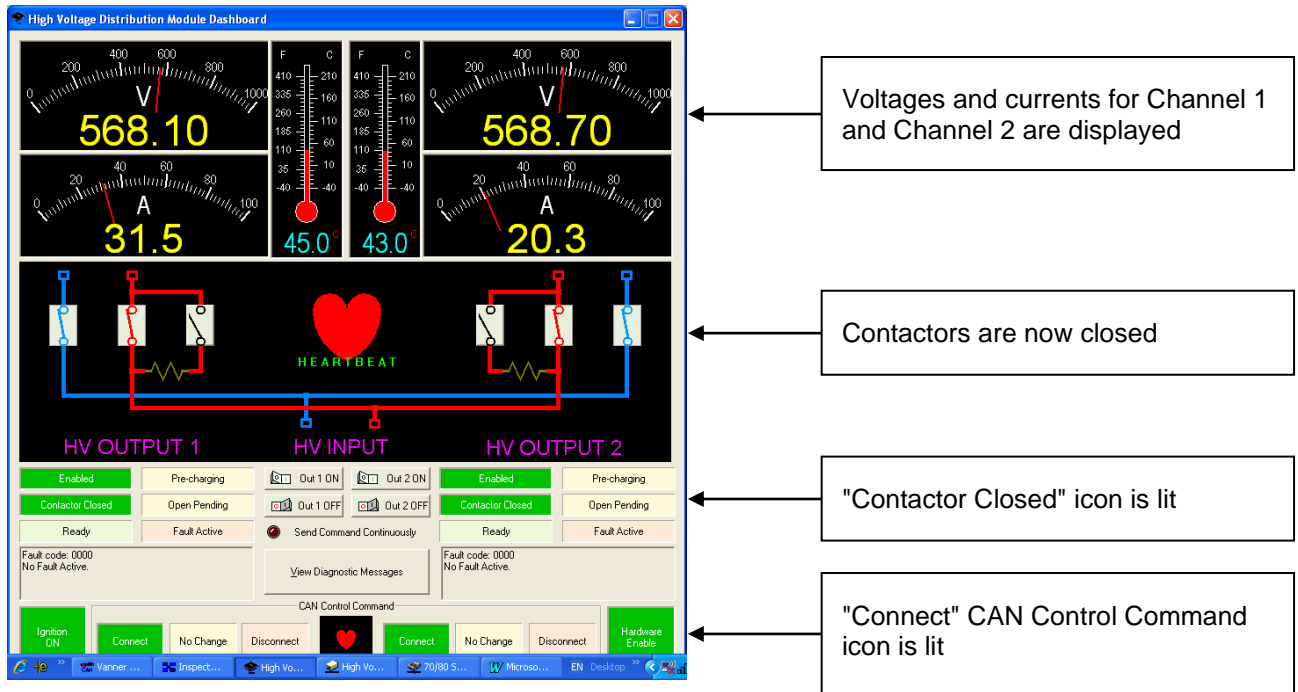

Trouble Shooting an HVDM No-Start Situation

In the event Channel 1 and/or Channel 2 contactors do not close, the following need to be reviewed/validated;

1. Is the capacitive load $\leq 6,800\mu\text{F}$?
2. Is there a short circuit on the output of either channel?
3. Is the high voltage battery within the acceptable input range of 400 - 800VDC?
4. Is the low voltage battery within the acceptable range of 18 – 32VDC?
5. Are the high voltage terminations tightened to the proper torque value?
6. Are the high voltage fuses in place and installation hardware tightened to the proper torque value?
7. Is either high voltage fuse blown?
8. Is the HVIL switch in place and the plunger free to travel?
9. Is the enclosure cover in place and all hardware installed?
10. Is the external HVIL connector fully seated?
11. Is the rectangular I/O connector fully seated?
12. Are the +24V, Ignition, CAN and enable signal wires terminated in the proper locations of the rectangular I/O connector?
13. Is the +24V ignition signal present upon vehicle startup?
14. Is the enable signal, active low, working properly?

Trouble Shooting an HVDM Abnormal Contactor Open Situation

The following conditions will cause a contactor to open:

1. The 24V wakeup signal is lost/off.
2. The hardware enable signal is lost or turned off.
3. The input voltage exceeds 860V.
4. The channel current exceeds 160A.
5. The temperature at the input/output terminals exceeds 95°C.

Note: For additional troubleshooting assistance, reference the "Distribution Module Abnormal Conditions" section for conditions that will flag faults and affect contact closure.

CAN Bus Specification

High Voltage Distribution Module CAN Communication Specification

A comprehensive CAN communication specification is available for the HVDM. Please contact Vanner's engineering department to ensure you have the latest revision.

Notes

**Vanner Incorporated
4282 Reynolds Drive
Hilliard, Ohio 43026**

**1-800-AC POWER
(1-800-227-6937)
Tel: 614-771-2718
Fax: 614-771-4904**

**www.vanner.com
e-mail: pwrsales@vanner.com**

**Part Number D916153-D
April 26, 2021
Printed in U.S.A.**